



## *Stackable Locker Systems*

---

U.S. Door & Building Components' ready-to-assemble lockers provides an economical alternative for low-cost unit rental. Lockers provide building owners with an ability to market free or low cost rental space as a way to encourage new and additional rental business.

Easily affordable, these lockers add rentable space to any facility, rapidly paying for themselves. Fitting under stairs, in oversized hallways, or stacked together in unrentable units, lockers provide additional revenue by utilizing vacant space. Various configurations and sizes are available.

U.S. Door & Building Components offers design assistance in the conversion of empty space into rentable storage. Stackable Storage Lockers by U.S. Door are shipped ready-to-assemble quickly and easily increasing your rentable space.



**Standard Locker** - designed to fill the basic cost conscious need for additional modular storage units.

**Vented Locker** - Otherwise known as "climatized storage", these lockers are designed to provide additional space in air conditioned buildings

Vented lockers "breathe" and maintain the same temperature and humidity

as the room they are contained in, allowing environmental controls in the surrounding area to affect the interior of the locker.

**Wine Storage Locker** - designed specifically for the wine storage market, these lockers offer flush doors, airflow design, and easy-to-load sub floor. Air flow maximizes humidity

control, an essential element in proper wine storage. U.S. Door's Stackable Storage Lockers are designed with functionality as well as appearance in mind. Available in three standard sizes, ideally fitting most case dimensions and configurations.

**STANDARD FEATURES:**

- Factory Pre-Painted in Gloss White
- Easy Bolt-Together Assembly
- All-Required Fasteners Included
- Chrome-Plated Slide Latch
- Stackable Design Provides Flexibility in Unit Mix Layout
- Hemmed Door Jambs Provide Safety and Security

**OPTIONS:**

- Stainless Steel Door
- Chateau Cylinder Core with 2 Keys

**STANDARD LOCKERS:**

- W x D x H**  
 24" x 24" x 48"  
 24" x 24" x 96"  
 36" x 36" x 36"  
 36" x 36" x 48"  
 36" x 36" x 96"

**STANDARD VENTED LOCKERS:**

- W x D x H**  
 28" x 28" x 32"  
 28" x 28" x 48"  
 28" x 28" x 64"

*Vented Lockers available without vents for additional standard locker sizes.*

**STANDARD WINE LOCKERS:**

- 30" x 28" x 34" (4 cases)  
 30" x 28" x 51" (8 cases)  
 30" x 28" x 68" (12 cases)

*Fits import or domestic case sizes*

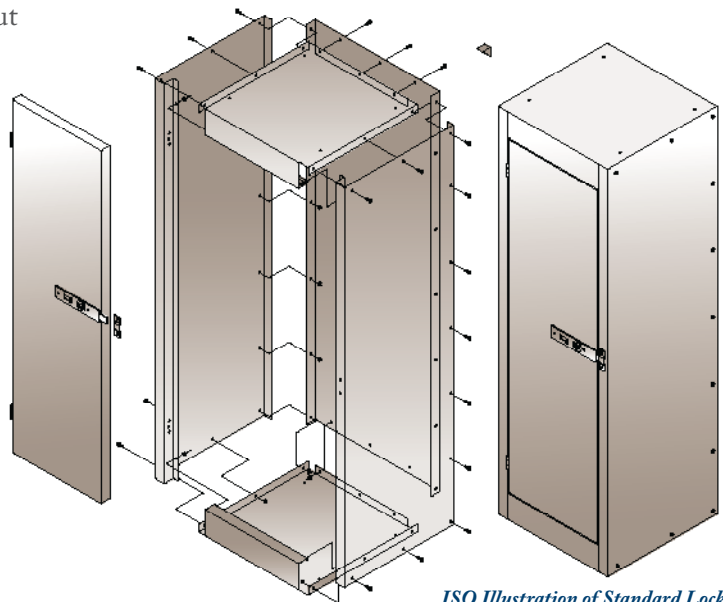

ISO Illustration of Standard Locker



Custom Designs

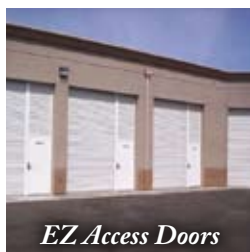

EZ Access Doors



Roll-Up Doors



Interior Hallways



Mezzanines



Relocatables



1720 West Broadway Rd. • Mesa, AZ 85202

10407 Rocket Blvd. • Orlando, FL 32824

Toll free 1-877-877-8875

TEL 407-859-6770

Fax 407-447-2923

[www.usdoor.com](http://www.usdoor.com)

[info@usdoor.com](mailto:info@usdoor.com)